

THE
Jones[™]
CENTER



THE
RUNWAY
BICYCLE SKILLS PARK

 IN PARTNERSHIP WITH





THE CONCEPT

“THE RUNWAY” is a first of its kind directional playground that creates a platform for all ages to develop the bike handling skills necessary to adopt cycling as a healthy active lifestyle choice while growing TJC offerings to include additional outdoor recreational amenities.



OVERVIEW

B - ULTRA BEGINNER

- 1 Sweeping Turn
- 2 Meandering Way
- 3 Box Top
- 4 Sweeping Turn
- 5 Triple Roller
- 6 Sweeping Turn
- 7 Boomerang
- 8 Low Roof Top
- 9 Flowing Z Turn

W - INTERMEDIATE WEST LINE FLOW COURSE

- 1 Right Wooden Berm
- 2 Left Wooden Berm
- 3 Double Roller
- 4 3' Wall Ride
- 5 Single Roller
- 6 4' Wall Ride
- 7 Ditch
- 8 4' Wall Ride
- 9 4' Triple Roller
- 10 20" Table Top
- 11 Switch Back

E - INTERMEDIATE EAST LINE SKILL COURSE

- 1 Sweeping Turn
- 2 Rooftop
- 3 Sweeping Turn
- 4 Rock Garden
- 5 Funnel
- 6 Twist & Turn
- 7 Barn Roof
- 8 Boardwalk
- 9 Rock Garden
- 10 Step Down



PARK DETAILS

“THE RUNWAY” consists of several different types of cycling specific amenities including directional beginner and intermediate “lines” packed with sustainable, minimum maintenance features as well as 2 different pump tracks, a balance bike specific course, and custom features users will find nowhere else in the country other than The Jones Center — all designed to develop the bike handling skills necessary to navigate the growing miles of paved and soft-surface trails throughout the Region.

THE
Jones[™]
CENTER



✈ THE PLANE

- Modeled after a P-51 built to the same specs with a 32' long body and a 37' wingspan
- Maximum 3' in height and minimum 4' wide with custom printed playground quality rubber padding surrounding the feature
- Serves as a main "hub" for the 3 specific feature filled lines
- Blends aviation and cycling together in ways never done before
- Runway "95" recognizes the year TJC was established

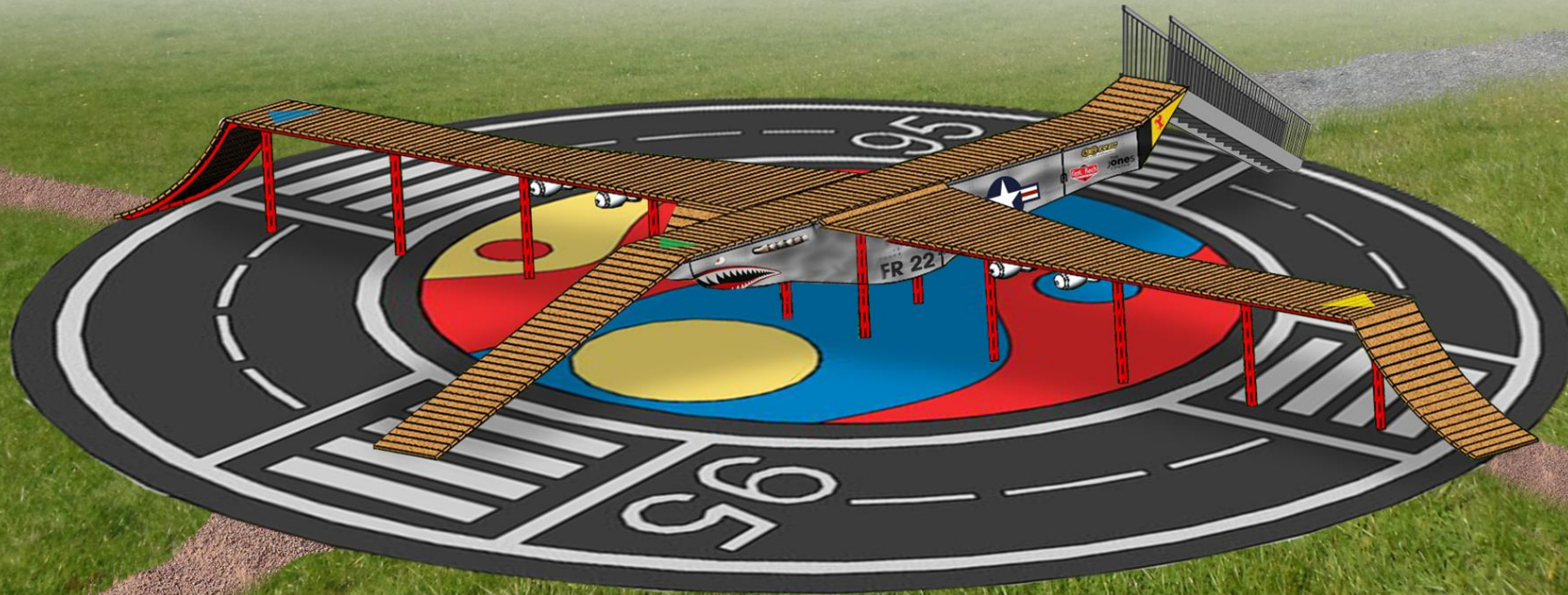

www.fastrackmcs.com



LINE ELEMENTS

ULTRA BEGINNER

Easy, flowing layout that is suitable for beginners, families and children. The Ultra Beginner Line hosts several minor obstacles that are ideal for introducing less experienced riders to the more technical skills useful on soft-surface trails.

- 1 Sweeping Turn
- 2 Meandering Way
- 3 Box Top
- 4 Sweeping Turn
- 5 Triple Roller
- 6 Sweeping Turn
- 7 Boomerang
- 8 Low Roof Top
- 9 Flowing Z Turn

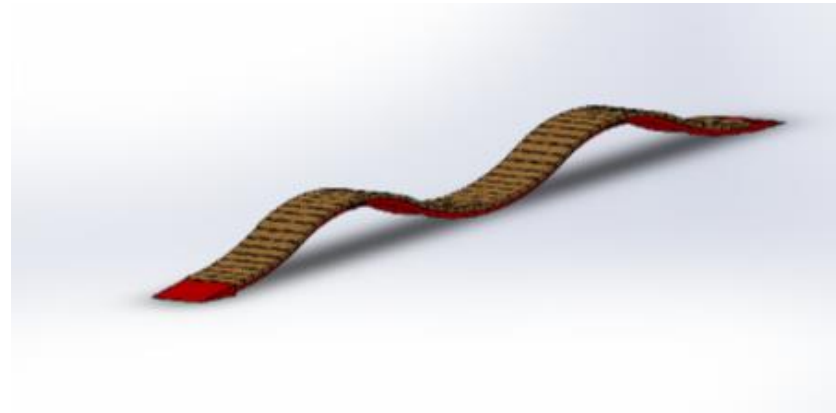

LINE ELEMENTS

INTERMEDIATE WEST LINE FLOW COURSE

More advanced flow line that will cater to riders progressing past beginner riding levels. With obstacles built to teach riders to carry speed and find their “flow”, this course will help riders become more comfortable with berms, wall rides and tighter turns.

- 1 Right Wooden Berm
- 2 Left Wooden Berm
- 3 Single Roller
- 4 3' Wall Ride
- 5 Double Roller
- 6 4' Wall Ride
- 7 Ditch
- 8 4' Wall Ride
- 9 Triple Roller
- 10 Table Top
- 11 Switch Back

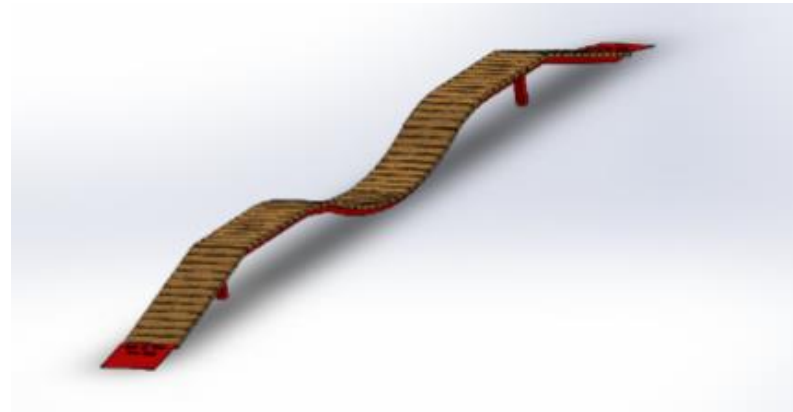

LINE ELEMENTS



INTERMEDIATE EAST LINE SKILL COURSE

More advanced skills course that will cater to riders progressing past beginner riding levels. With obstacles built to simulate intermediate soft-surface trails, this course will help riders become more comfortable with changing elevation, narrowing passages and rougher terrain.

- 1 Sweeping Turn
- 2 Rooftop
- 3 Sweeping Turn
- 4 Double Rock Garden
- 5 Funnel
- 6 Twist & Turn
- 7 Barn Roof
- 8 Boardwalk
- 9 Triple Rock Garden
- 10 Step Down



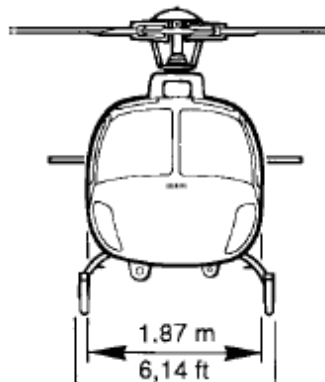
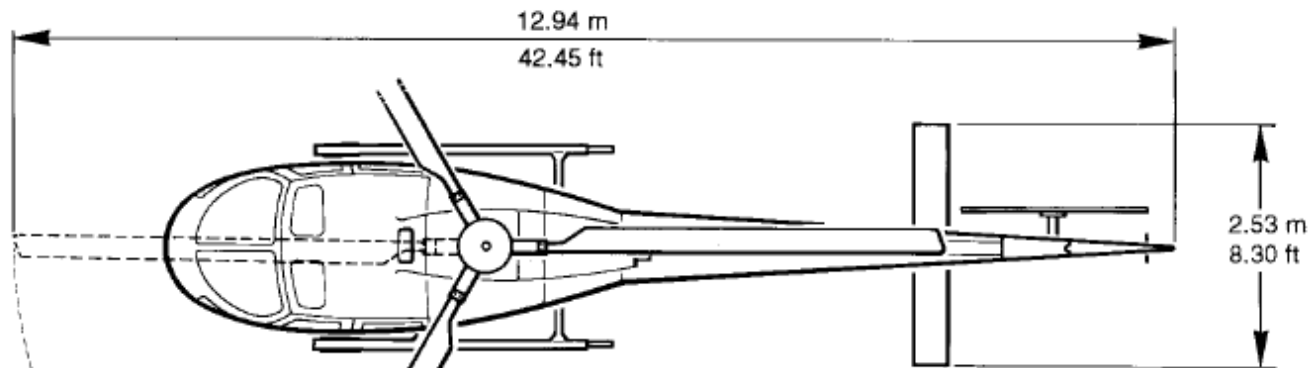
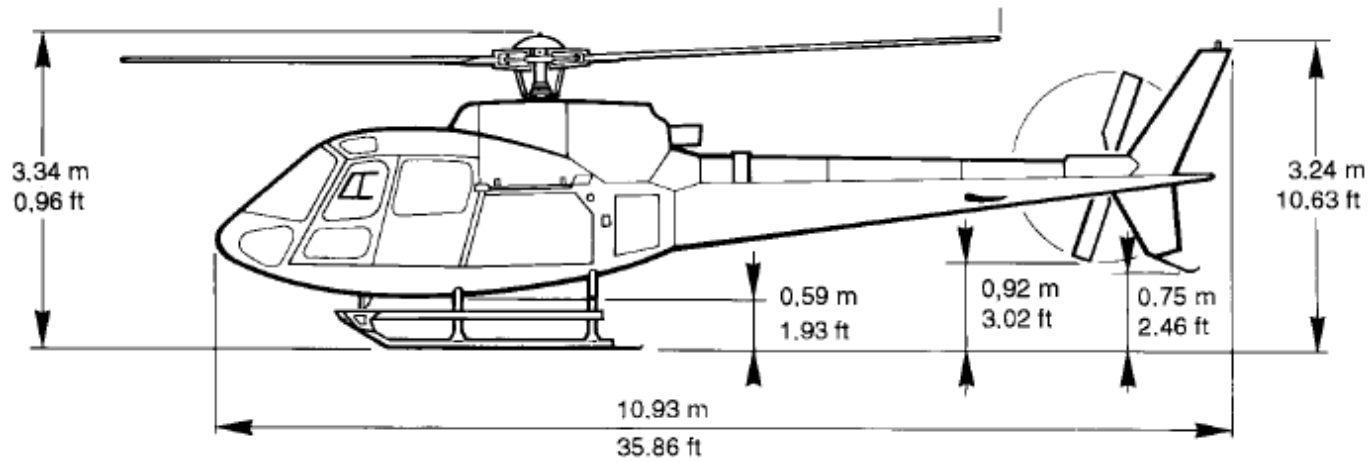

✈ THE COPTER

- Utilizes a real A-Star Helicopter with custom fabrication by craftsman who's work has been featured on the cover of Trucking Magazine and more
- All 3 lines feeding into copter were designed specifically to curb speed prior to approach
- Features a single roller through the middle of a real piece of avionic equipment
- Custom printed playground quality rubber padding featuring the "J" from TJC



ADDITIONAL ELEMENTS AND DETAILS

In addition to the directional flow and skills lines “THE RUNWAY” features several other elements and details specifically designed to grow cycling skill levels and provide a safe “experience” unique to the Jones Center including:

- A main return or “Taxi Runway” through the middle of park for users to return to the main hub (plane) or any of the various other amenities
- 30” wide features, 6” wider than the industry standard for additional stability and ease of use, and limited to a maximum 48” high
- Custom beginner and intermediate Pump Tracks, one of the newest forms of cycling specific amenities
- Balance bike optimized 36” wooden course for children as young as two years old to start to develop skills including following a designated “preferred” line to help them navigate the course



ELEMENTS AND DETAILS CONTINUED

- Strategically placed covered pavilion designed to provide protection from the elements for users and non-users that is passed each time before taking another “run” on the directional courses
- Easily accessible “fueling” or hydration stations to promote proper hydration while outdoors
- Specifically placed Information Hub providing new users detail of the park, it’s amenities, and any rules required to promote safe use.
- Additional themed sign package throughout the park for accessibility and safety including “Do Not Enter” and “Directional” arrows as necessary



OVERVIEW

B ULTRA BEGINNER

- 1 Sweeping Turn
- 2 Meandering Way
- 3 Box Top
- 4 Sweeping Turn
- 5 Triple Roller
- 6 Sweeping Turn
- 7 Boomerang
- 8 Low Roof Top
- 9 Flowing Z Turn

W INTERMEDIATE WEST LINE FLOW COURSE

- 1 Right Wooden Berm
- 2 Left Wooden Berm
- 3 Double Roller
- 4 3' Wall Ride
- 5 Single Roller
- 6 4' Wall Ride
- 7 Ditch
- 8 4' Wall Ride
- 9 4' Triple Roller
- 10 20" Table Top
- 11 Switch Back

E INTERMEDIATE EAST LINE SKILL COURSE

- 1 Sweeping Turn
- 2 Rooftop
- 3 Sweeping Turn
- 4 Rock Garden
- 5 Funnel
- 6 Twist & Turn
- 7 Barn Roof
- 8 Boardwalk
- 9 Rock Garden
- 10 Step Down



HIGHLIGHTS

- A world class outdoor recreational amenity that creates an unique experience that users will find nowhere else but The Jones Center
- Generates new focus to the property and engages new demographics while adding value to the community by growing the offerings of The Jones Center to include outdoor recreational opportunities
- Specifically designed to develop the bike handling skills necessary to navigate the growing miles of paved and soft-surface trails throughout the Northwest Arkansas Corridor
- Will bookend the current improvements to the Downtown Springdale area and be a true showcase for the Region
- Creates new branding and marketing opportunities to highlight The Jones Center and it's mission to strengthen the community and make it a better place to live